

Optical Encephalography

Model: Spectratech OEG-16

User's Manual – Summary

Technical Edition Rev 1.3

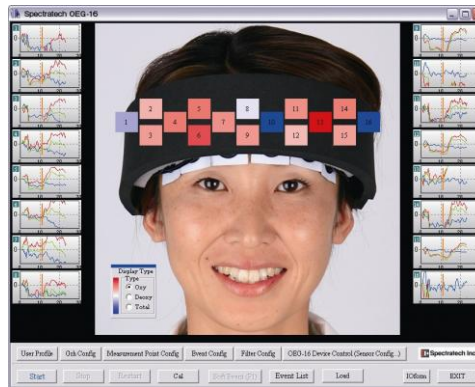

Note:

As this equipment was developed for **research purpose** use only, you are kindly requested not to use it for other purposes. Please carefully read through this manual prior to use because it is a very precise equipment.

Version	Date of issue	Remarks
V 1.1	November 8,2010	First version
V1.2	July 9,2012	2 nd Version
V1.3	May 23,2014	Explanation of §3 Acquisition principle of biological information was revised.

Message for users

The equipment is just one that captures a change of blood flow rate in the frontal lobe if it is simply said. It is an indispensable equipment for a brain researcher to challenge the issue of brain function measurement of which importance has risen more and more in the 21st century. However, it also has a possibility in which the examinee may suppose that his/her heart was unwillingly looked into different from the researcher's intention unless it arranges an enough explanation, and carefully considered experimental environment and experimental issues for him/her before the experiment. We strongly hope you to understand and consider the issue when this equipment is used.

If the 20th century is assumed to be the age of shape diagnostics representing CT and MRI, the 21st century may be called the age of functional diagnostics with the equipments such as PET, fMRI, and fNIRS (Near- infrared reflectance spectrometry: Our device is a kind of fNIRS). However, it is said that the functional diagnostics still have a lot of issues to be researched. Understanding such historical background, we developed the Optical Encephalography Spectratech OEG-16 to be of some help for broadening the base of the research.

We agree that there still are a lot of issues that should be improved as an equipment. So, we will welcome the pep talks from you, the brain researchers.

We wish you, the brain researchers the best success in your researches.

Mitsuo Ohashi, President
Spectratech, Inc.
November 8, 2009

Table of content

- §1 Brief overview
- §2 Features
- §3 Acquisition principle of biological information
- §4 Specification
- §5 Configuration
- §6 Usage environment and utility form
- §7 Connection condition for external devices

Remarks 1 When multiple equipments are operated synchronously with external event inputs

§1 Brief overview

The equipment is designed to simultaneously measure a change of the amount of blood in each in vivo part not so deep in by the multi-channel (up to 16 channels) method. It utilizes the light absorption characteristics in the neighborhood of near infrared to red light that changes with the bonding state of the in vivo hemoglobin (Hb) with oxygen. The spread spectrum modulation method that is the latest digital technique and originally developed by our company is adopted for the optical modem technology that underlies the equipment. It has achieved great reduction in costs, downsizing, and high performance compared with the conventional technologies. It is assumed that the equipment is used mainly on the frontal lobe part that has few hairs. So, a simple and non-invasive measurement is possible, and it is also considered to use it for a battery-powered mobile measurement system, and simultaneous measurements for multiple examinees.

In addition, the equipment has been developed consistently for research purpose, so you are kindly requested not to use it for other purposes.

The equipment can be used in stand-alone mode, or by connecting with PC with a USB port and Microsoft Windows XP/VISTA /7 installed.

§2 Features

- (1) Small-sized Main unit (about half the size of a notebook PC), suitable also for mobile measurement
- (2) Dedicated design for use on the frontal lobe.
- (3) Adoption of spread spectrum modulation in the latest light modulation technology.
- (4) 6 light-emitting points, 6 light-receiving points, and 16 measurement points/channels.
- (5) Event-related designs and block designs are available.
- (6) Synchronous operation with other measurement device (TTL level input) such as triggers.
- (7) Event signal input from an external device such as stimulus presentation PC (TTL level), or by manually inserted input.
- (8) Signal bandwidth of oxyhemoglobin and deoxyhemoglobin: 0.76Hz (0.65sec sampling time).
- (9) Real-time measurement and display with PC connected via USB port.
- (10) Operation with AC input, or battery.
- (11) Operation with battery only for up to 1 hour for mobile measurement.
- (12) Continuous operation with AC power input for up to 10 hours.
- (13) Carrying bag for mobile measurement (detachable).
- (14) Simultaneous measurement by multiple units (hyper-scanning) to record multiple subjects. Up to 5 units with the optional Distributor are available.

§3 Acquisition principle of biological information

Based on the Beer-Lambert law, assuming that the incident light intensity to a solution in a certain density is I_{in} , and the light intensity that got through the solution is I_{out} , it is known that the following expression is true.

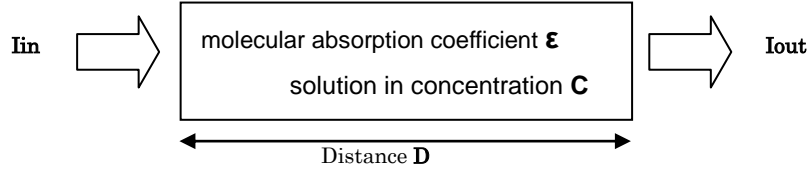

$$-\text{Log} (I_{out} / I_{in}) = \epsilon \times C \times D$$

That is, if molecular absorption coefficient ϵ of the solution in a specific wavelength was obtained beforehand, the concentration C of the solution can be obtained by measuring I_{in} , I_{out} , and D .

The following is the modified Beer-Lambert Law, that is applied to a medium with scattering by extending the Beer-Lambert Law

$$-\text{Log}(I_{out} / I_{in}) = \epsilon \times C \times D + S$$

Here, S represents the attenuation of the light intensity by scattering. D represents the average optical path length.

When in solution concentration (solute) is changed to $C + \Delta C$ from C , the amount of transmitted light has changed to $I_{out} + \Delta I_{out}$, it becomes

$$-\text{Log} [(I_{out} + \Delta I_{out}) / I_{in}] = \epsilon \times (C + \Delta C) \times D + S$$

When the attenuation S of scattering light intensity does not change, it is shown by the formula from two equations above.

$$-\text{Log} [(I_{out} + \Delta I_{out}) / I_{out}] = \epsilon \times \Delta C \times D$$

Of the incident light intensity to live body in a specific wavelength, defined as $I_{out}(\lambda)$ to a light intensity has returned to in vitro in response to the scattering and absorption in vivo, $\Delta I_{out}(\lambda)$ to a amount of change. the molecular absorption coefficient of oxyhemoglobin (OxyHb) is $\epsilon_{oxy}(\lambda)$, deoxyhemoglobin (DeoxyHb) is $\epsilon_{deoxy}(\lambda)$, the concentration change of OxyHb is ΔC_{oxy} , and the concentration change of DeoxyHb is ΔC_{deoxy} , this equipment is designed presuming that the following expression is true.

$$-\text{Log} [(I_{out}(\lambda) + \Delta I_{out}(\lambda)) / I_{out}(\lambda)] = (\epsilon_{oxy}(\lambda) \times \Delta C_{oxy} + \epsilon_{deoxy}(\lambda) \times \Delta C_{deoxy}) \times D$$

From this expression, the concentration change of OxyHb ΔC_{oxy} and the concentration change of DeoxyHb ΔC_{deoxy} are obtained.

Here, there are two variables to be obtained such as ΔC_{oxy} , ΔC_{deoxy} , therefore the equipment obtains them using the near-infrared molecular absorption coefficient in two wavelengths such as 770 nm and 840 nm shown below

$$-\text{Log}[(I_{out}(\lambda 840) + \Delta I_{out}(\lambda 840)) / I_{out}(\lambda 840)] = (\epsilon_{oxy}(\lambda 840) \times \Delta C_{oxy} + \epsilon_{deoxy}(\lambda 840) \times \Delta C_{deoxy}) \times D$$

$$-\text{Log}[(I_{out}(\lambda 770) + \Delta I_{out}(\lambda 770)) / I_{out}(\lambda 770)] = (\epsilon_{oxy}(\lambda 770) \times \Delta C_{oxy} + \epsilon_{deoxy}(\lambda 770) \times \Delta C_{deoxy}) \times D$$

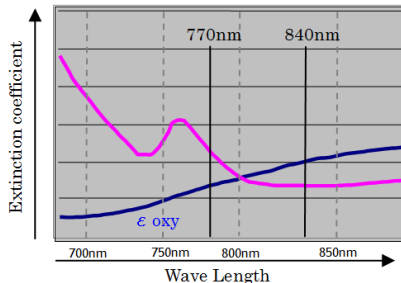

And, from $D \times \Delta C_{oxy}$, $D \times \Delta C_{deoxy}$ obtained from the above expressions,

$$D \times \Delta C_{oxy} + D \times \Delta C_{deoxy} = D \times \Delta C_{total}$$

as calculated above, it is assumed to be a total Hb change ($D \times \Delta C_{total}$).

As for the unit of Hb change ^{Note 1} ($D \times \Delta C_{oxy}$, $D \times \Delta C_{deoxy}$, and $D \times \Delta C_{total}$), it uses mM·cm (millimolar centimeter) or mM·mm (millimolar millimeter) that still contains a light path length because it cannot be specified.

Note 1: From now on, $D \times \Delta C_{oxy}$, $D \times \Delta C_{deoxy}$, and $D \times \Delta C_{total}$ shall be called **Hemoglobin change (Hb change)**, to be exact The product of change in the apparent Hb concentration and the optical pathlength. As the simplified symbol representations, $\Delta C_{oxy} \cdot L$, $\Delta C_{deoxy} \cdot L$, and $\Delta C_{total} \cdot L$, or $\Delta C_o \cdot L$, $\Delta C_d \cdot L$, and $\Delta C \cdot L$ are used respectively.

2) Light modulation

When being tried to obtain the multipoint biological information at the same time, it can separate off where the light that reached a sensor came from. There, the light modulation technology is used. The equipment has adopted the spread spectrum multi-modulation method for the light modulation, that is one of the latest digital technologies.

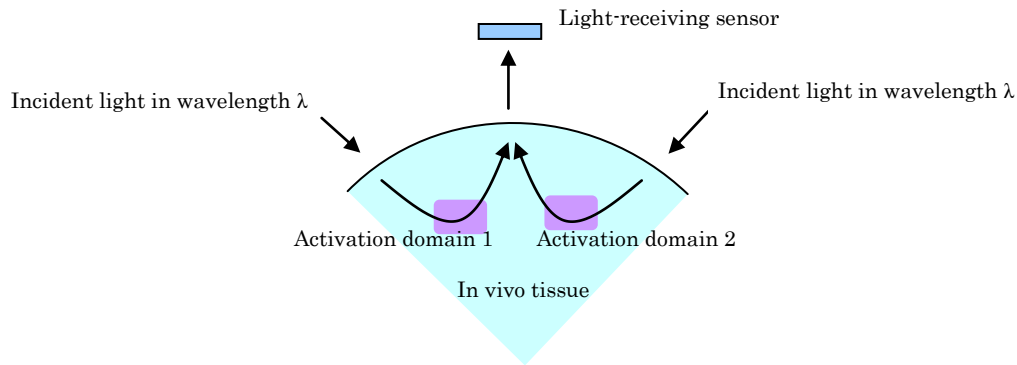

On the other hand, CDMA (Code Division Multiple Access), that is, the spread spectrum modulation is one of the most advanced modulation technologies, that is used for the recent mobile phones or GPS of car navigation systems. It is a modulation method that uses random numbers. Though it is rather difficult to understand the essential theory, it has the advantages in less influenced by turbulence light, simultaneous measurement, no big problem for multiple channels, and the actual circuit scale won't be so large. So, NIRS (Near Infrared Reflectance Spectroscopy) including our equipment generally use the near-infrared ray in continuous wave (CW: Continuous wave) as a light source. TDMA (Time Division Multiple Access) or FDMA (Frequency Division Multiple Access) has been known as optical multi-modulation method in CW. This equipment has adopted CDMA (Code Division Multiple Access) that is quite different from the technique. CDMA is generally called spread spectrum modulation method from the principle. TDMA (Time Division Multiple Access) or FDMA (Frequency Division Multiple Access) has been known as optical multi-modulation method in CW. The equipment has adopted CDMA (Code Division Multiple Access) quite different from the conventional technique. CDMA is generally called spread spectrum modulation method from the principle.

TDMA is a method that controls each light source at the micro level, and a light source in a specific place emits a light at a certain moment. The sensor side where a light was received can separate off the light that came from a specific point by controlling the time. Though it is extremely advantageous in easy-to-use as a modulation method, it still has the disadvantages in easily influenced by turbulence light, and limitation to the biological signal bandwidth for multiple channels.

FDMA method light-modulates the light of each source at individual frequency to emit it. The sensor side where lights were received can separate off the lights that came from each point by separating them off with a frequency-dependent filter after changing the optical composite signal from each point into an electrical signal. It becomes less influenced by the turbulence light compared with TDMA, and is advantageous in its simultaneous measurement. Though it has the disadvantage in necessity of designing a precise frequency-dependent filter, complex circuit scale, and extreme difficulty for supporting multiple channels when exceeding a certain scale, it still is a light modulation technology with good prospects.

Overview of TDMA method

In the figure below, only the light source 1 lights up at the time 1, and the light is received at each receiving point. It is the method to light up sequentially with time such as the light source 2 at the time 2, the light source 3 at the time 3, and so on in the same way.

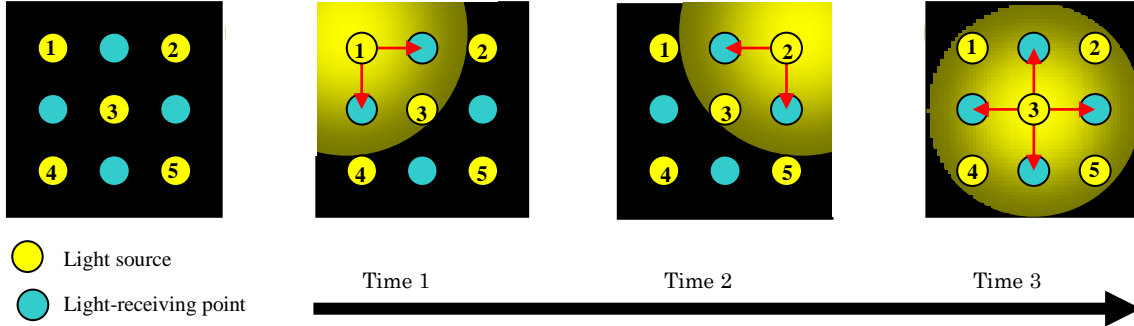

Overview of FDMA method

In the figure below, the light sources 1~5 repeat lighting up at the same time at different modulation frequency. It is a method to specify the point and the optical signal strength at each receiving point by utilizing the different modulation frequency of a light signal from each light source even if each light source lights up at the same time.

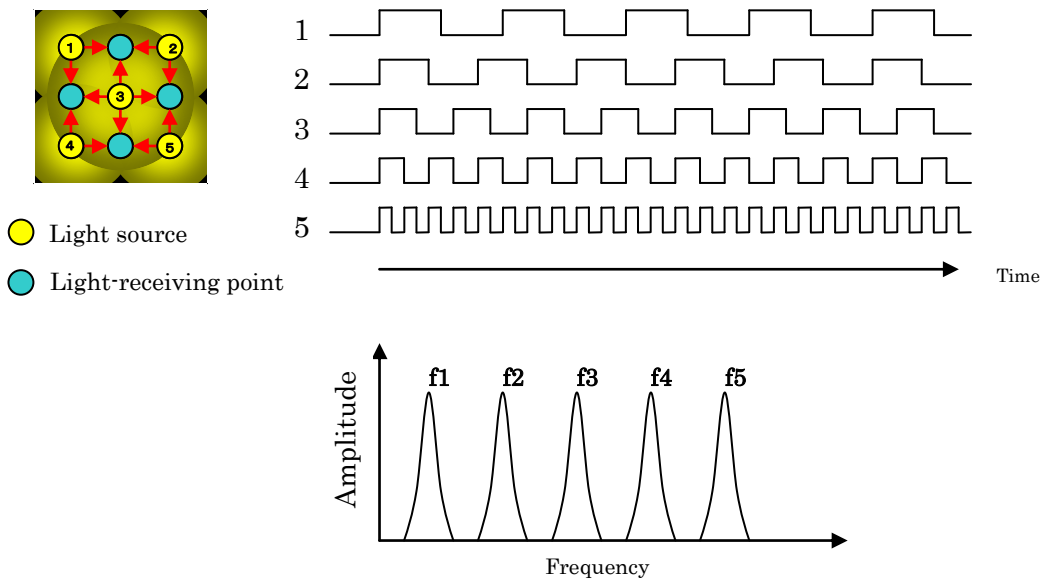

Overview of CDMA (Spread spectrum modulation) method

In the figure below, the light sources 1~5 modulate with different random numbers, and repeat lighting up. The method is to specify the point and the optical signal strength at each receiving point by utilizing the difference in random number code of the optical signal from each light source even if each light source lights up at the same time.

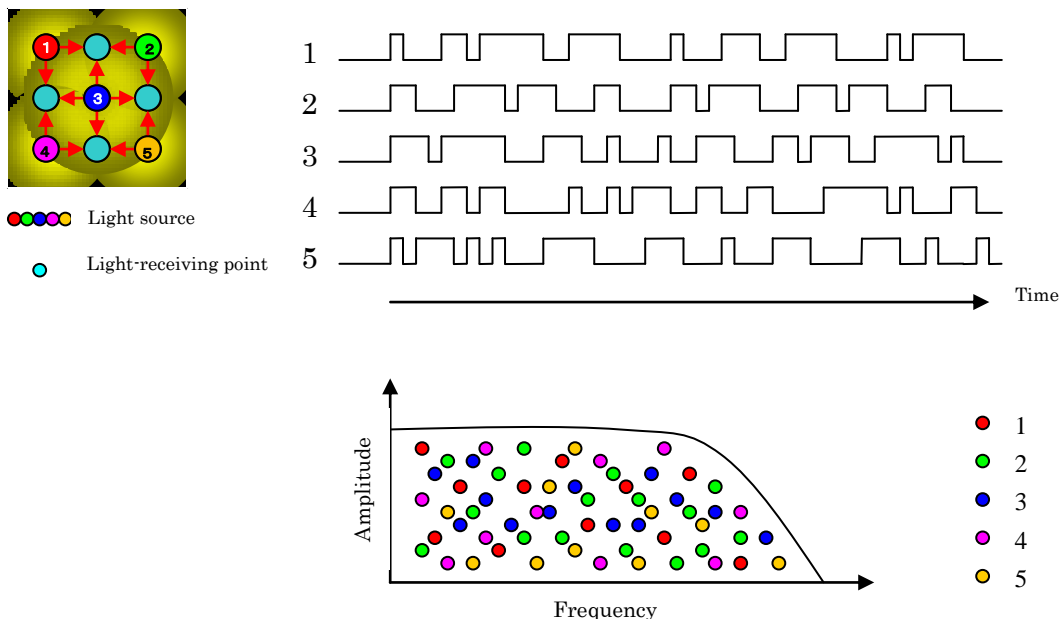

Feature of each method (Use for light measurement)

Light modulation method	TDMA (Time Division Multiple Access)	FDMA(Frequency Division Multiple Access)	CDMA (Code Division Multiple Access)
Principle	Simple	Complex	Difficult
Simultaneous measurement	△	⊙	⊙
Multi channels	△	○	⊙
High SN ratio	Limited bandwidth	Limited bandwidth	Available in various methods
Influence by disturbance noise	Large (Depending on modulation method)	Little	Very little
MODEM circuit	Simple/Small size	Complex/Large scale	Simple/Small scale
Practical application	Transmission packet of Internet	Terrestrial digital broadcasting (13-segment OFDM (Orthogonal Frequency Division Multiplexing))	Mobile phone GPS (Used for car navigation system)

§4 Specification

Spectratech OEG-16-01 Head Module

1) Light emitting part

Six units equipped

Built-in type LED with two waves (Wavelength 1: 840nm 2: 770nm)

Output power: 3.8mW/770nm, 3.4mW/840nm max. on surface of light emitting part

Safety of laser products (IEC 60825-1): Exempted

Reference: It was decided to exempt LED from IEC 60825-1 at IEC/TC 76 (Optical radiation safety and laser equipment) conference on October 11~15, 2004.

NORME INTERNATIONALE INTERNATIONAL STANDARD PUBLICATION GROUPEE DE SECURITE GROUP SAFETY PUBLICATION	CEI IEC 60825-1 <small>Deuxieme edition Second edition 2007-03</small>	2007-03 IEC 60825-1 から抜粋 Light emitting diodes (LEDs) have been removed from the scope of this part of IEC 60825, but may still be included in other parts.
		In previous editions, LEDs were included in the scope of IEC 60825-1, and they may be still included in other parts of the IEC 60825 series. However, with the development of lamp safety standards, optical radiation safety of LEDs in general can be more appropriately addressed by lamp safety standards. The removal of LEDs from the scope of this Part 1 does not preclude other standards from including LEDs whenever they refer to lasers. CIE S009 may be applied to determine the risk group class of an LED or product incorporating one or more LEDs.

2) Light-receiving part

Six units equipped

Si PIN photo diode with visible light cutoff filter

3) Number of simultaneous measurement channels

16 channels

4) Distance between light injection part and optical light-receiving part

3cm

Note: The head module is assumed to use on the frontal lobe part that has few hairs. It is not recommended to use it on other part. **In addition, even if it is measured on the frontal lobe with little hairs, the device's sensor may not sense because some of the examinees might have extremely weak signals. Please be forewarned.**

Spectratech OEG-16 Main unit

1) Measuring method of biological signal

Based on the modified Beer-Lambert Law

Measurements of ΔCoxyHb , $\Delta\text{CdeoxyHb}$, and $\Delta\text{CtotalHb}$

2) Optical multi-modulation method

Modulation method: Spread spectrum modulation DS (Direct Sequence) method ^{Note 1}

PN CODE: M-sequence code (Code length: 65535 bits)

Effective bandwidth of biological signal: 0.76Hz (Sampling interval: 0.65 seconds)

3) Event input function

It can input an event trigger manually at an appropriate time using the accessory box (Spectratech OEG-16-05 with entry acknowledge LED).

4) External trigger input function

(1) It equips two systems of the photo-isolated “external trigger input block” to work cooperatively with external devices. It is connected with external devices via BNC cable for external signal input (Spectratech OEG-16-04 accessory). It accepts the usage in both the external event trigger and external measurement/record start trigger.

Input condition: TTL level (Isolated by photo-coupler in the main unit)^{Note 2}

(2) Possible to input from other PC via Network (Use of UDP protocol)

Details of how to use from Network are described in **§6 and §7 in Applied Technology Edition.**

5) Measurement time

(1) AC power supply Continuous measurement for up to about 10 hours

(2) Battery operation Continuous measurement for up to about 1 hour

6) Connection with PC

It is connected with PC with a USB port and Windows XP , VISTA or 7 via the USB cable for PC connection (Spectratech OEG-16-06 accessory). And, the Installation software (Spectratech OEG-16-07 accessory) is installed so that PC can output various commands, and record or display the measurement data received.

7) Built-in battery

For main part of Main unit:

4 x AA battery (Continuous operation for about 1 hour)

For photo isolation part:

2 x AA battery (Continuous operation for about 6 months)

For internal clock:

CR2032 Lithium battery (Continuous operation for about 3~5 years)

8) The latest firmware can be downloaded from PC/website as needed.

Note 1:

The DS (Direct Sequence) method is one of the spread spectrum signal generation methods, called direct diffusion method as well, and modulates by using the random numbers called spread code sequence (PN sequence). In addition, there is FH method (Frequency Hopping) method.

Note 2:

TTL input means +3~+5V digital signal input at high impedance.

§4 Configuration

Spectratech OEG-16 consists of the following components.

- 1) Spectratech OEG-16 Main unit ······ 1 set
- 2) Spectratech OEG-16-01 Head module ······ 1 set
- 3) Spectratech OEG-16-02 Optical Phantom ······ 1 set
- 4) Spectratech OEG-16-03 Carrying bag ······ 1 set
- 5) Spectratech OEG-16-04 BNC cable for external signal input ······ 2 sets
- 6) Spectratech OEG-16-05 Box for manual event trigger input ······ 1 set
- 7) Spectratech OEG-16-06 USB cable for PC connection ······ 1 set
- 8) Spectratech OEG-16-07 Install software in CD-ROM ······ 1 set
- 9) AC adaptor (+5V2A output,Medical Grade) ······ 1 set
- 10) User's Manual ······ 1 set

1) Spectratech OEG-16 Main unit ······ 1 set Spectratech OEG-16

Front side of Main unit



- POWER:** It is the power switch. Pushing the upper part turns it ON. When the power is supplied by either of AC adaptor or battery and it is ready to operate, LED on the button lights up.
- START:** It is the button to start measurement/recording. Pushing the button will start measurement/recording, and LED on the button lights up to indicate starting operation. Pushing the button cannot start operation unless an in vivo calibration was done with CAL button, and CAL LED lights up. If START button is pushed again during a measurement/recording (LED lighting up), it restarts another measurement/recording from the point when it was pushed again after deleting the recorded data till then. It is useful when a recording is started in spite of insufficient preparation when starting a measurement, which may often happen.
- STOP:** It is the button to stop measurement/recording. Pushing the button will stop the measurement/recording. Green LED in the button lights up to indicate the confirmation of the stop.
Multiple tasks can be measured and recorded by repeating START/STOP. Recording time of the record memory in Main unit is about ten hours. Even if START button was pushed, it doesn't begin to record when the memory is full. When the memory became full, please send off the data to PC once for processing the memory to be cleared.
- EVENT:** The button is pushed when an event trigger is input manually from the front side of Main unit. It corresponds only when it is being measured. The manual event trigger input is prepared also on the rear side of Main unit.
- CAL:** It is the button for the in-vivo calibration. In case of AUTO mode being described in the separate Software Edition, please push the button once before beginning a measurement after installing the head module to a live body. The LED blinks during the calibration, and becomes in lighting-up state when the calibration ended, then it is possible to measure. It always lights up in case of MANUAL mode, and it can start a recording at any time without performing the calibration process.
In addition, the LED is blinking a little bit faster during the calibration. If it still blinks slowly after the calibration, it warns that some channels are out of the specified signal range. Please confirm the mounting condition of the sensors to the live body. Even under such condition, a measurement/recording can begin.
- BATT:** It lights up (Red) when the capacity of the battery (4 x AA battery) for the main part of Main unit fell to less than the rated value, it lights up (Red). In case of battery operation, please exchange the battery with charged one soon when the LED lighted up. Continuous operating time of the battery is limited in one hour. In addition, it does not guarantee one hour in operation of the equipment with batteries other than ENELOOP of SANYO. Please use ENELOOP without fail.

Rear side of Main unit



- SENSOR L:** Cable L for Spectratech OEG-16-01 Head module is connected to.
- SENSOR R:** Cable L for Spectratech OEG-16-01 Head module is connected to.
- EXT-EVENT-IN 1:** It is used for the measurement/recording start input or the event trigger input from external devices via Spectratech OEG-16-04 BNC cable for external signal input. It can be used also by connecting the accessory BOX for Spectratech OEG-16-05 manual event trigger input (however, LED on BOX does not carry out lighting operation).
- EXT-EVENT-IN 2:** It is used for the event trigger input from external devices via Spectratech OEG-16-04 BNC cable for external signal input. It can be used also by connecting the accessory BOX for Spectratech OEG-16-05 manual event trigger input (however, LED on BOX does not carry out lighting operation).
- REMOTE:** Cable from Spectratech OEG-16-05 Box for manual event trigger input is connected to. An event trigger can be input manually from this Box besides EVENT switch on the front side of Main unit. Green LED on the Box lights up when an event trigger was accepted.
- USB:** It is connected to PC with Spectratech OEG-16-06 USB cable for PC connection when various commands are given to Spectratech OEG-16 Main unit from USB, or PC receives measurement data from the Main unit.
- DC-IN:** Cable from the attached AC 110V adaptor is connected to. It is used when operating by connecting to PC, or the battery operation is not wanted despite an independent operation by Main unit.
- GND:** It is the earth terminal. Please surely connect it to a ground in an environment where it is available.

Battery 4 x AA: For main part of Main unit Battery

Please equip the battery set in case of battery-powered operation of Spectratech OEG-16 Main unit. It consists of four AA batteries. It is capable of continuous operation for about 1 hour. When the capacity becomes insufficient, BATT-LED on the front side of Main unit lights up (Red) to warn it. When the LED lighted up, please exchange the battery set with charged one soon. When the LED turned on during a measurement/recording, the recording is automatically ended, the data is saved, and it is put into halt state. In addition, it does not guarantee one-hour operation of this equipment with batteries other than ENELOOP of SANYO. Please use ENELOOP without fail.

Battery 2 x AA: For photo isolation part

The battery set is used when EXT-EVENT-IN 1 or EXT-EVENT-IN 2 of Spectratech OEG-16 Main unit is connected to external device. It consists of two AA batteries. Since use of this battery makes a complete optical isolation between an external device and Main unit, external devices can be connected safely. It can be used continuously for about 6 months. When EXT-EVENT-IN1 or 2 is not used, this battery need not be equipped.

2) Spectratech OEG-16-01 Head module 1 set

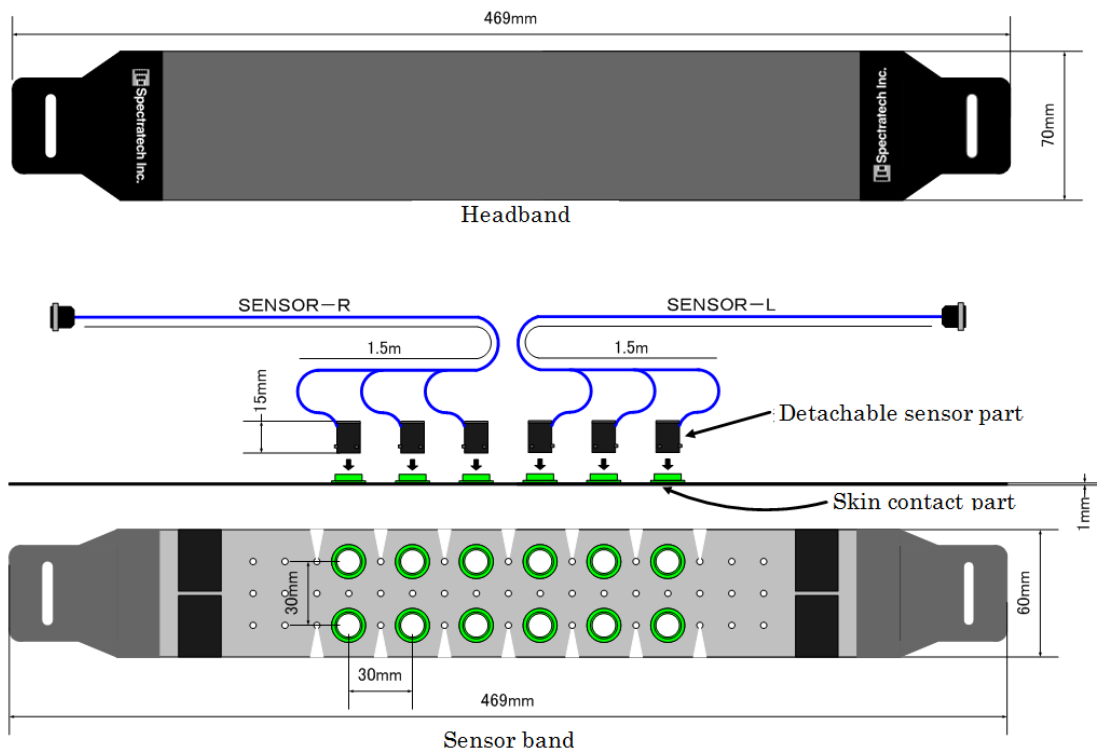

It is the high-sensitivity part that is attached to the head to obtain biological information. It consists of the precisely made optical components. Please handle it carefully.

The signal lines from each sensor part of the head module are concentrated into the two connectors. Please connect the connector of Cable L to SENSOR L, and that of Cable R to SENSOR R on the rear side of Main unit.

In addition, it is recommended to wipe off oil and dust, etc. on the sensor part with rubbing alcohol before it is installed to the live body.



3) Spectratech OEG-16-02 Optical Phantom 1 set

This optical phantom is used to confirm that each light-emitting part/light-receiving part of the head module part works properly. The confirmation method is described later.



4) Spectratech OEG-16-03 Carrying bag 1 set

This bag is an accessory to take along Spectratech OEG-16 Main unit for performing a mobile biological measurement. It is possible to take along it on his/her back like a rucksack, by putting it on his/her shoulder, or wrapping it around his/her waist. **In addition, it is not a situation in which an optical mobile measurement of the brain function can be performed practically under the present situation. However, our company, in the situation where even mobile experiment has not been able to be done up to now dared to produce it so that the researchers may do various research experiments to put it to practical use in the future.**



5) Spectratech OEG-16-04 BNC cable for external signal input 2 sets

The two BNC cables are used to start a measurement/recording by Main unit or to input Event trigger from external devices. One end of the BNC cable is connected to EVENT-IN 1 or 2 on the rear side of Main unit, and the other one is connected to the output terminal of the external device with BNC connector that can be used for measurement/recording start or Event trigger. The Main unit corresponds to TTL output from the external devices. When the output specification of the external device does not meet TTL output, please contact our company or our agency without forcibly connecting it.

6) Spectratech OEG-16-05 Box for manual event trigger input (3m cable attached) 1 set

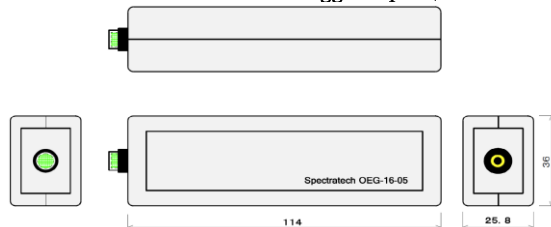

This Box assumes to be use when it is required to input an Event input manually a little distance away from Main unit during a measurement/recording. Connector on the cable end of this BOX is connected to REMOTE terminal on the rear side of Main unit. When the button of this Box is pushed during a measurement/recording, it is input as an Event trigger, and when it was acknowledged by Main unit, LED on the button lights up to indicate it.

7) Spectratech OEG-16-06 USB cable for PC connection 1 set

When various commands are given to SpectratechOEG-16 Main unit from PC, or PC obtains measurement data from Main unit, this cable is used to connect Main unit with PC.

8) Spectratech OEG-16-07 Install software in CD-ROM 1 set

Installing this CD-ROM software on PC makes it possible to use the application software for Main unit. PC with a USB port, and Windows XP/VISTA installed is required.

9) AC adaptor for AC 110V (Domestic use) 1 set

When SpectratechOEG-16 Main unit is not operated with the battery, the DC output cable of this adaptor is connected to DC-IN on the rear side of Main unit. It works with the domestic single phase AC 110V in U.S.A. As the adaptor conforms to the domestic specification please do not use it in other countries.

10) User's Manual 1 set

It includes various instructions for this equipment. User's Manual is also stored in PDF format in the CD-ROM of Spectratech OEG- SpO₂-07 Installation software.

*** AA battery Not include**

SpectratechOEG-16 Main unit has two storage spaces on the side to store the batteries. One can house four AA Batteries, and the other does two AA batteries.

The set of four batteries is necessary for battery-powered operation of Main unit. A new set is capable of a continuous operation of Main unit for about 1 hour. When the capacity becomes insufficient, BATT-LED on the front side of Main unit lights up (Red) to warn it. When the LED lights up, please exchange the batteries with charged ones.

When the LED lights up during a measurement/recording, the recording is automatically ended, the data is saved, and it is put into halt state.

The other battery set (2 x AA) is used when an external device is connected. Since use of this battery set makes a complete optical isolation between the external device and Main unit, the external devices can be connected safely. It can be used continuously for about 6 months. When EXT-EVENT-IN1 or 2 is not used, this battery set need not be equipped.

§6 Usage environment and utility form

Usage environment

The usage environment should be at ordinary temperature inside the room.

Temperature of usage environment: 5°C~30°C

Humidity of usage environment: 20%~70% (Not condensed)

Waiting time to measurement: Please start a measurement **5~7 minutes** at least after installing the sensor to the live body. It takes time until temperature of the sensor becomes equal to the body temperature.

Utility form

Spectratech OEG-16 has the following utility forms.

- 1) PC-Online 1 (Real-time waveform is displayed on PC while measuring. AC input operation.)
- 2) PC-Online 2 (Real-time waveform is displayed on PC while measuring. Two units operate simultaneously. AC input operation.)
- 3) PC-Offline 1 (Measuring only with Spectratech OEG-16 with battery. Waveform is displayed on PC connected after measurement.)
- 4) PC-Offline 2 (Measuring only with Spectratech OEG-16 with AC input. Waveform is displayed on PC connected after measurement.)

1) PC-Online 1 (Real-time waveform is displayed on PC while measuring. AC input operation.)

It is the most popular utility form. A measurement/recording is processed by one SpectratechOEG-16 connected to PC as the measurement result is being monitored in real time.

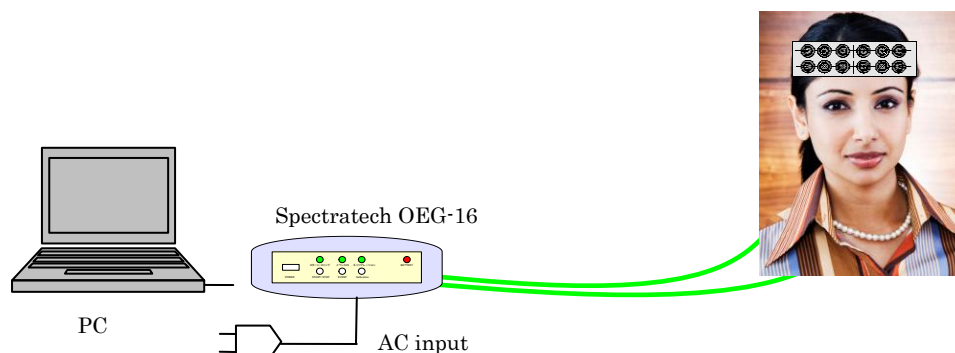

2) PC-Online 2 (Real-time waveform is displayed on PC while measuring. Two units operate simultaneously. AC input operation.)

Two SpectratechOEG-16 are concurrently connected to one PC, and measurement/recording of two examinees is performed simultaneously, and the work is processed while monitoring the measuring process in real time. PC should have two USB ports or more in this case.

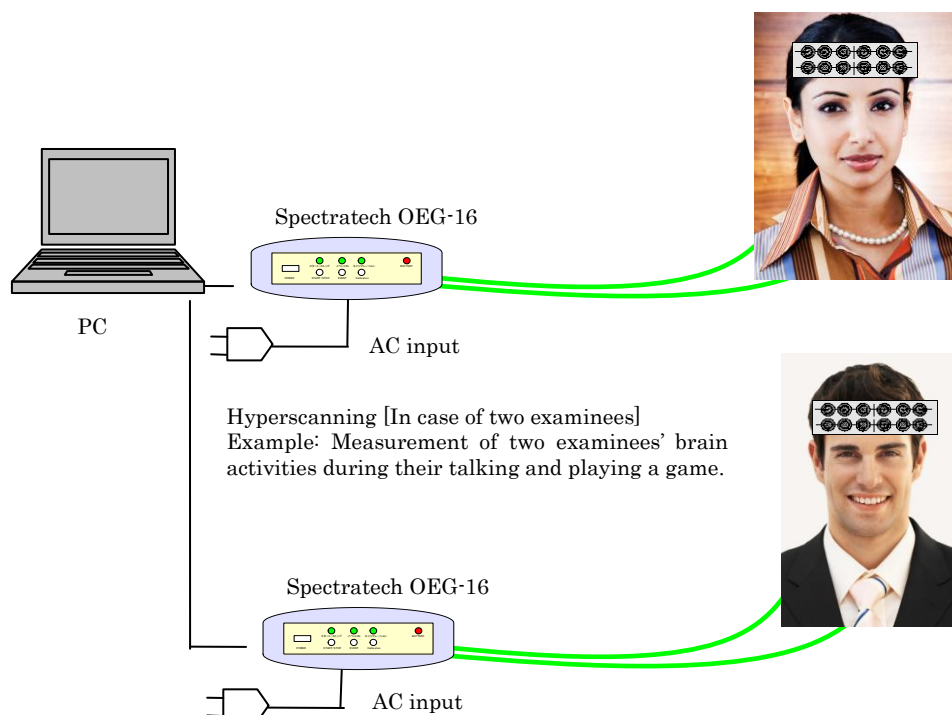

3) PC-Offline 1 (Measuring only with Spectratech OEG-16 with battery. Waveform is displayed on PC connected after measurement.)

The examinee can move freely while measuring because of battery-powered operation. It can continuously measure/record for up to one hour. However, please refrain from strenuous movement because of a cause of artifact (Artifact: Irrelevant noise to the biological signal, movement of the head, for instance).

In addition, it is not a situation in which an optical mobile measurement of the brain function can be performed practically under the present situation. However, our company, in the situation where even mobile experiment has not been able to be done up to now dared to produce it so that the researchers may do various research experiments to put it to practical use in the future.

First stage When measuring —— (Moving freely with battery) ——

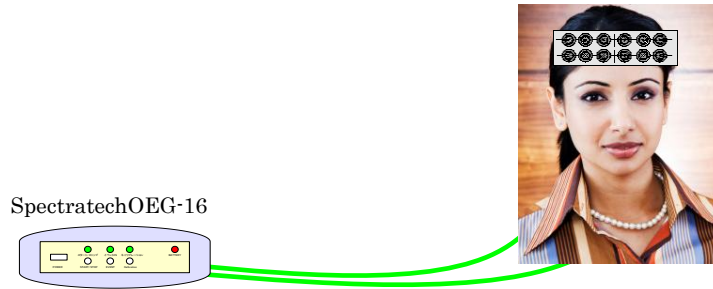

Second stage DATA collection + Wave shape display —————

It can collect from multiple Spectratech OEG-16 units.

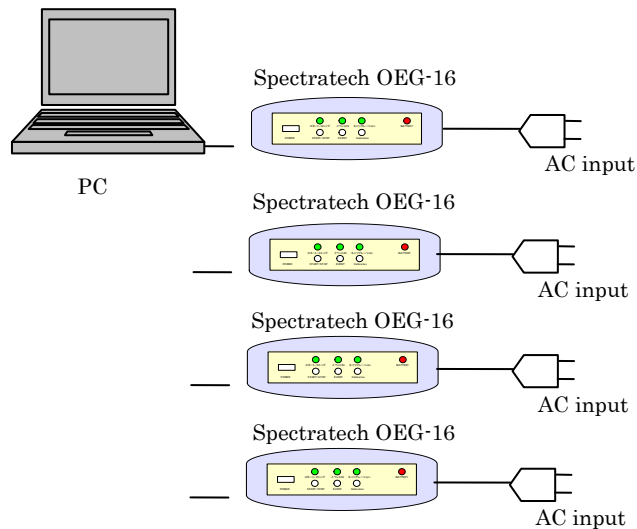

Hyperscanning:
 Simultaneous measurement of four examinees
 Example: Measurement of the brain activities while a group of four examinees are acting in class.

4) PC-Offline 2 (Measuring only with Spectratech OEG-16 with AC input. Waveform is displayed on PC connected after measurement.)

It is convenient when collecting the data that do not move. It can measure/record continuously for up to 10 hours.

First stage When measuring ——— (Main unit only with AC input) ———

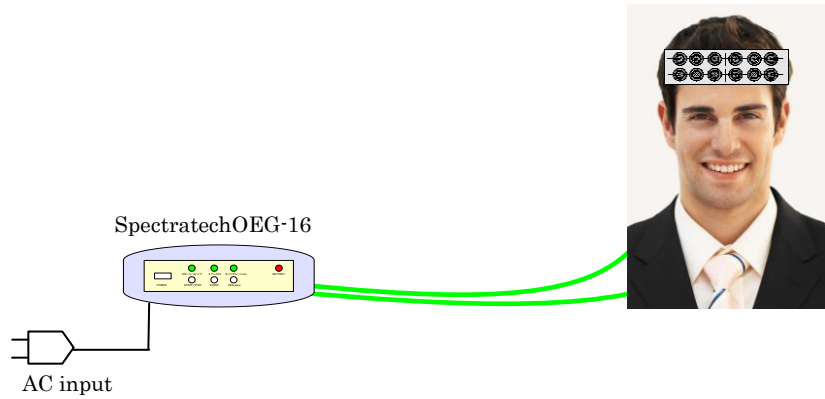

Second stage DATA collection + Wave shape display ———

It can collect from multiple Spectratech OEG-16 units.

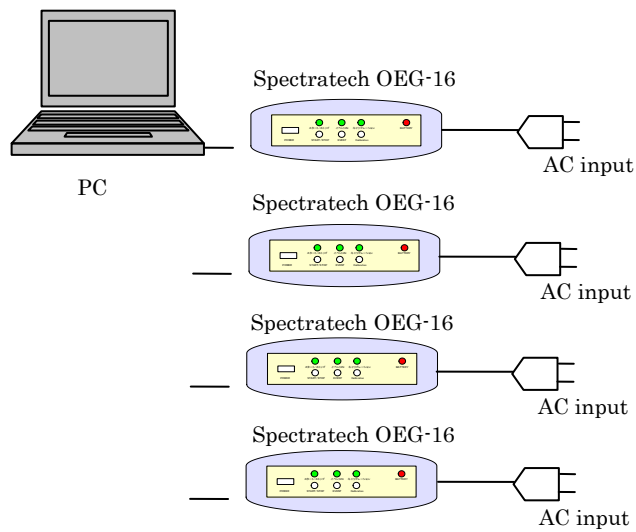

§7 Connection condition for external devices

In general, SpectratechOEG-16 receives a trigger signal of an external device for a simultaneous measurement, for example and starts a measurement synchronous with the external device (EXT-EVENT-IN1). If the measurement is a block design measurement (after-mentioned), for example, Spectratech OEG-16 automatically receives the event start information at the starting point of speech stimulation by a speech stimulus presentation device, and the event (EXT-EVENT-IN2) is captured. In addition, the following connection condition is provided, for example when an event that a measurer wanted to mark occurred the measurer occasionally pushes the switch (Spectratech OEG-16-05 Box for manual event trigger input) in hand to input the event (At this time, Main unit informs the measurer that it was confirmed to have accepted the event by blinking the LED of the switch in hand.), and uses it when processing the measurement data afterwards.

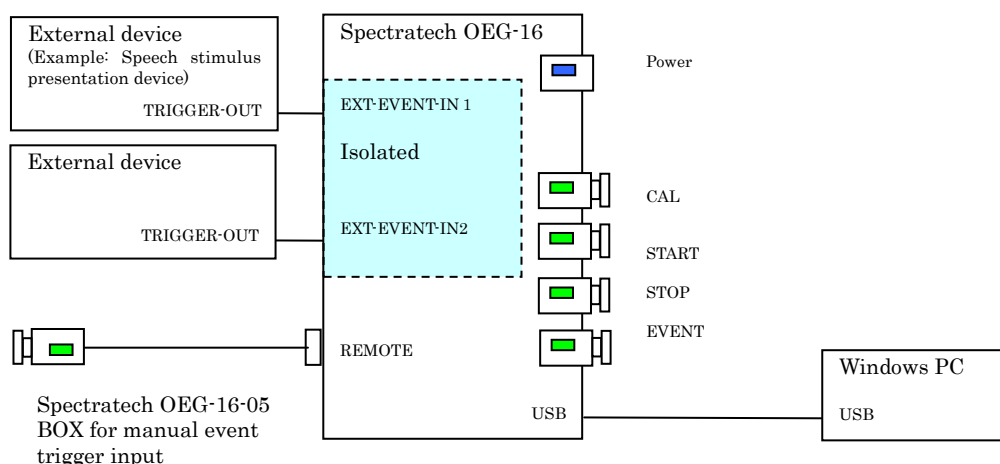

EXT-EVENT-IN1 can be switched by setting from PC when OEG-16 starts a measurement/record and an event trigger is input. EXT-EVENT-IN2 is only for the event trigger input. Therefore, it can operate connecting an external device that causes an event trigger to both IN1 and IN2. As the event input information is individually recorded in Main unit including manual event input from REMOTE, EVENT input on front side of Main unit, and icon click on PC, PC can separately display when which event was input afterward. display is good which event at which time input when PC displays them later.

In addition, as EXT-EVENT-IN1 and IN2 are photo-isolated, the external devices can be connected safely. Please surely load the two batteries in Battery2 (Power supply for the photo isolation) on the side of Main unit when EXT-EVENT-IN1 and IN2 are used. It can be used continuously for about half a year in normal use.

Remarks 1 When multiple equipments are operated synchronously with external event inputs

When multiple OEG-16's operate with one Trigger factor/Event factor, the following connections possible using the optional Spectratech OEG-16-101 and Spectratech OEG-16-102. Though the figure below shows a simultaneous connection diagram for up to 5 sets, the operation by six or more sets is also possible with the cascade connection of Spectratech OEG-16-101 and 102.

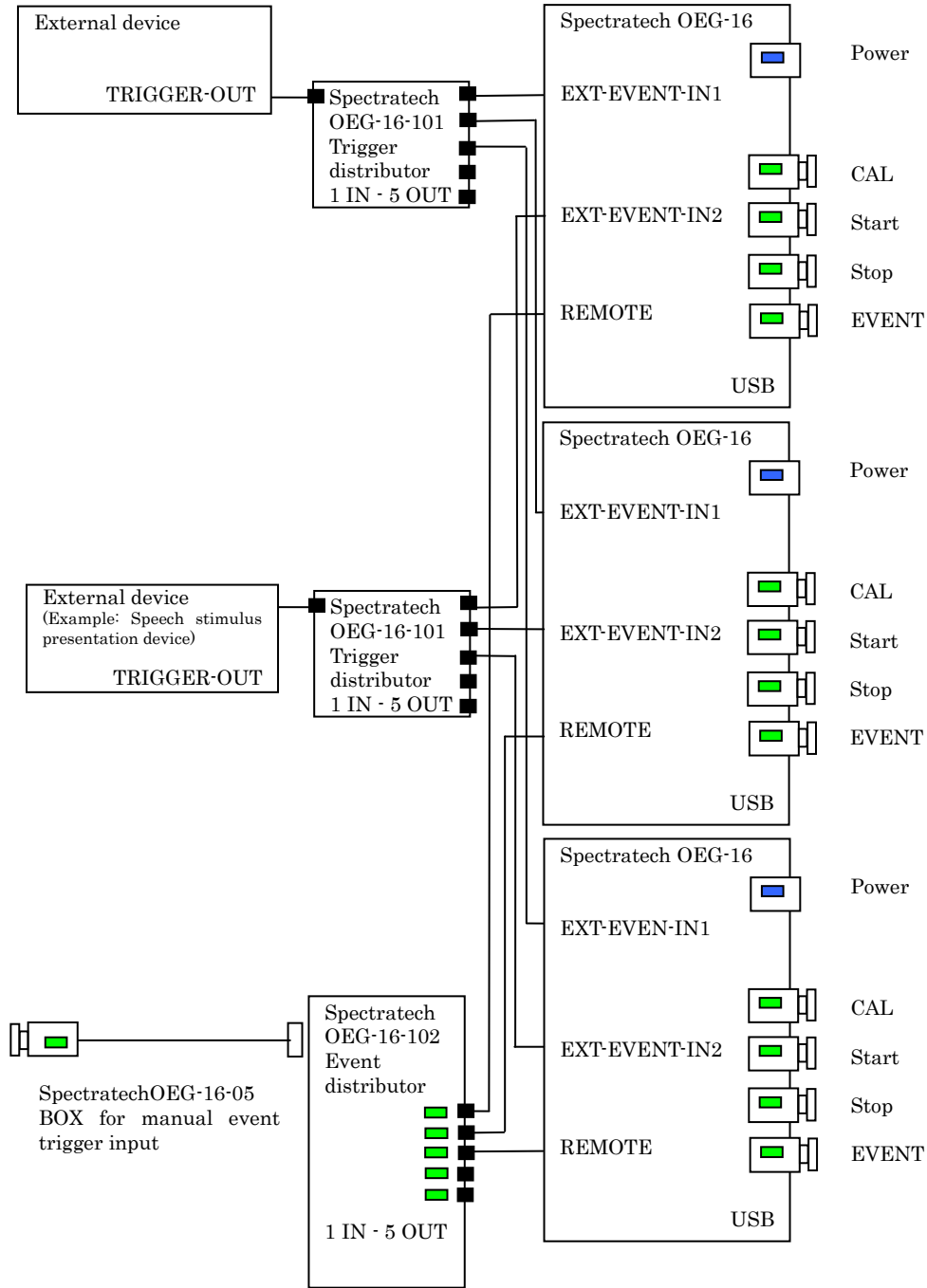

Spectratech OEG-16-101 Trigger distributor 1 IN 5 OUT Outline dimensional drawing

Dimension: 25mm (H) x 90mm (W) x 45mm

Material: Plastic

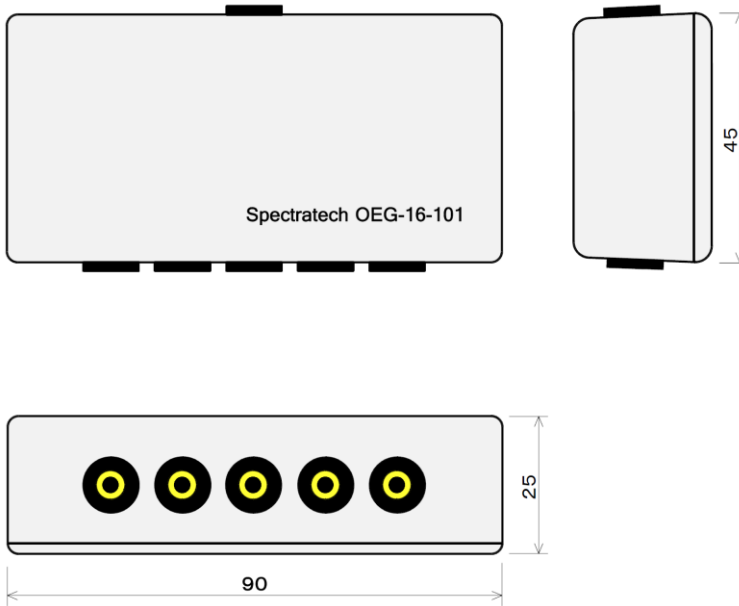

Spectratech OEG-16-102 Event distributor 1 IN 5 OUT Outline dimensional drawing

Dimension: 25mm (H) x 90mm (W) x 45mm

Material: Plastic

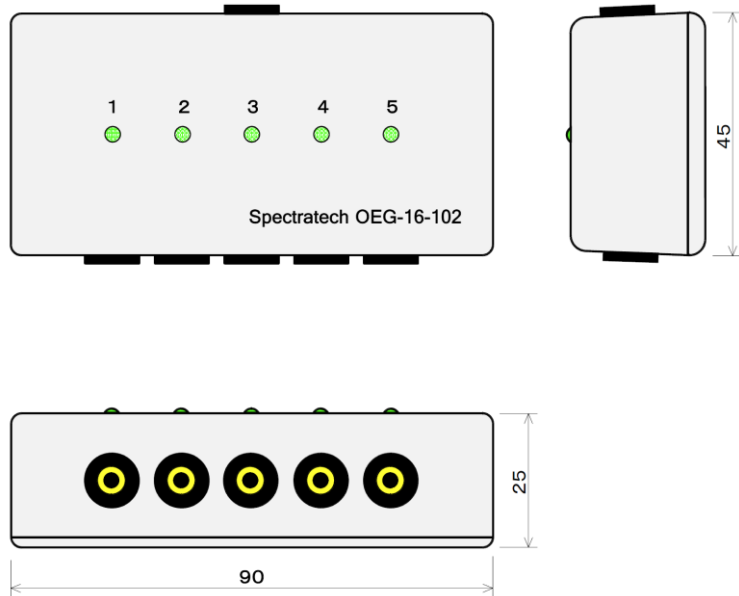

www.spectratech.co.jp



Spectratech Inc.

This user's manual is subject to change due to improvement of product, etc.
Copyright Spectratech Inc. 2008 All right reserved.
Spectratech OEG is a registered trademark of Spectratech, Inc.

Spectratech, Inc.

Headquarters 4-22-3 Kaminoge, Setagaya-Ku, Tokyo 158-0033 Japan

Sales Office 3rd Floor, New Yokohama IO Bldg. 1-3-10 Shin-Yokohama,
Kohoku-Ku, Yokohama-City, Kanagawa-Prefecture 222-0033 Japan
Phone: 81-45-471-4893 Fax: 81-45-471-4894